

Modular Cooking Range Line thermaline 90 - 7 lt Well Freestanding Electric Deep Fat Fryer, 1 Side H=700

ITEM # _____

MODEL # _____

NAME # _____

SIS # _____

AIA # _____



589296 (MCFAEADDAO) 7lt electric Deep Fat Fryer,
 one-side operated

Short Form Specification

Item No. _____

Unit constructed according to DIN 18860_2 with 20 mm drop nose top and 70 mm recessed plinth. Internal frame for heavy duty sturdiness in stainless steel. 2 mm top in 1.4301 (AISI 304). Flat surface construction, easily cleanable. THERMODUL connection system enables seamless worktop when units are connected and avoids soil penetrating. Appliance designed to deep fry meat, fish and vegetables (french fries). Deep drawn V-shaped well with external heating elements to facilitate cleaning operations. Indirect oil heating system and uniform heat distribution for extended oil life. Electronic sensor for precise oil temperature control. Reduced power setting to melt solid fat. Oil can be easily drained via a ball-valve. All-round basin raised edges to protect against soil infiltration. Large overflow stamped area around the well. Overheat protection switches off the supply in case of overheating. Standby function saves energy and quickly recovers maximum power. Metal knobs with embedded hygienic silicon "soft" grip enable easier handling and cleaning. IPX5 water resistant certification.
 Configuration: Freestanding, One-side operated.

Main Features

- All major components may be easily accessed from the front.
- THERMODUL connection system creates a seamless work top when units are connected to each other thus avoiding soil penetrating vital components and facilitating the removal of units in case of replacement or service.
- Metal knobs with embedded hygienic "soft-touch" grip for easier handling and cleaning. The special design of the controls prevents infiltration of liquids or soil into vital components.
- Overheat protection: the temperature sensor switches off the supply in case of overheating.
- Large visible digital display manufactured in tempered glass to resist heat and chemicals, showing temperatures or power settings. The display also shows on/off status of the appliance and on/off status of the heating elements.
- Raised edge all around the well to protect from infiltration of dirt from worktop.
- Deep drawn V-Shaped well.
- Large overflow stamped area, located around the well.
- External heating elements allow to easily clean the well.
- Indirect oil heating system and uniform heat distribution to guarantee extended oil life.
- Reduced power setting to melt solid fat.
- Oil level mark for MAX/MIN filling.
- Designed for deep fat frying of meat, fish, specialities and vegetable (french fries, chips).
- Oil can be drained off via a ball-valve with a lock to prevent unintentional opening. When opened, the ball valve provides a full cross-section opening to easily clean the drainage system.
- Electronic sensor for precise oil temperature control.

Construction

- 2 mm top in 1.4301 (AISI 304).
- Unit constructed according to DIN 18860_2 with 20 mm drop nose top and 70 mm recessed plinth.
- Flat surface construction with minimal hidden areas to easily clean all surfaces
- IPX5 water resistance certification.
- Internal frame for heavy duty sturdiness in stainless steel.

Sustainability



- Standby function for energy saving and fast recovery of maximum power.
- This model is compliant with Swiss Energy Efficiency Ordinance (730.02).

APPROVAL: _____

Front

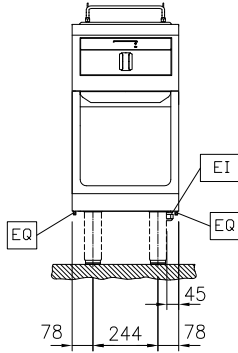

Side

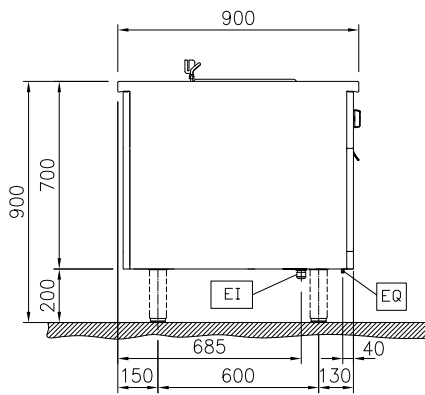

EI = Electrical inlet (power)
 EQ = Equipotential screw

Top

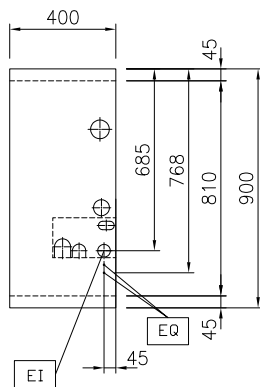

Electric

Supply voltage: 400 V/3N ph/50/60 Hz
 Total Watts: 5.4 kW

Key Information:

Number of wells: 1
 Usable well dimensions (width): 240 mm
 Usable well dimensions (height): 135 mm
 Usable well dimensions (depth): 380 mm
 Well capacity: 6 lt MIN; 7 lt MAX
 Thermostat Range: 100 °C MIN; 180 °C MAX
 External dimensions, Width: 400 mm
 External dimensions, Depth: 900 mm
 External dimensions, Height: 700 mm
 Net weight: 70 kg
 Configuration: On Base; One-Side Operated

Sustainability

Current consumption: 7.8 Amps

Included Accessories

- 1 of Filter for 2x5 and 7lt deep fat fryer oil collection basin PNC 913154

Optional Accessories

- Connecting rail kit, 900mm PNC 912502
- Stainless steel side panel, 900x700mm, freestanding PNC 912512
- Portioning shelf, 400mm width PNC 912522
- Portioning shelf, 400mm width PNC 912552
- Folding shelf, 300x900mm PNC 912581
- Folding shelf, 400x900mm PNC 912582
- Fixed side shelf, 200x900mm PNC 912589
- Fixed side shelf, 300x900mm PNC 912590
- Fixed side shelf, 400x900mm PNC 912591
- Stainless steel front kicking strip, 400mm width PNC 912630
- Stainless steel side kicking strip left and right, freestanding, 900mm width PNC 912657
- Stainless steel side kicking strip left and right, back-to-back, 1810mm width PNC 912663
- Stainless steel plinth, freestanding, 400mm width PNC 912954
- Connecting rail kit: modular 90 (on the left) to ProThermetic tilting (on the right), ProThermetic stationary (on the left) to ProThermetic tilting (on the right) PNC 912975
- Connecting rail kit: modular 80 (on the right) to ProThermetic tilting (on the left), ProThermetic stationary (on the right) to ProThermetic tilting (on the left) PNC 912976
- Endrail kit, flush-fitting, left PNC 913111
- Endrail kit, flush-fitting, right PNC 913112
- Endrail kit (12.5mm) for thermaline 90 units, left PNC 913202
- Endrail kit (12.5mm) for thermaline 90 units, right PNC 913203
- Stainless steel side panel, left, H=700 PNC 913222
- Stainless steel side panel, right, H=700 PNC 913223
- T-connection rail for back-to-back installations without backsplash (to be ordered as S-code) PNC 913227
- Insert profile d=900 PNC 913232
- Energy optimizer kit 14A - factory fitted PNC 913244
- Endrail kit, (12.5mm), for back-to-back installation, left PNC 913251
- Endrail kit, (12.5mm), for back-to-back installation, right PNC 913252
- Endrail kit, flush-fitting, for back-to-back installation, left PNC 913255

- Endrail kit, flush-fitting, for back-to-back installation, right PNC 913256
- Side reinforced panel only in combination with side shelf, for freestanding units PNC 913260
- Side reinforced panel only in combination with side shelf, for back-to-back installations, left PNC 913275
- Side reinforced panel only in combination with side shelf, for back-to-back installation, right PNC 913276
- Filter W=400mm PNC 913663
- Stainless steel dividing panel, 900x700mm, (it should only be used between Electrolux Professional thermaline Modular 90 and thermaline C90) PNC 913672
- Stainless steel side panel, 900x700mm, flush-fitting (it should only be used against the wall, against a niche and in between Electrolux Professional thermaline and ProThermetic appliances and external appliances - provided that these have at least the same dimensions) PNC 913688